

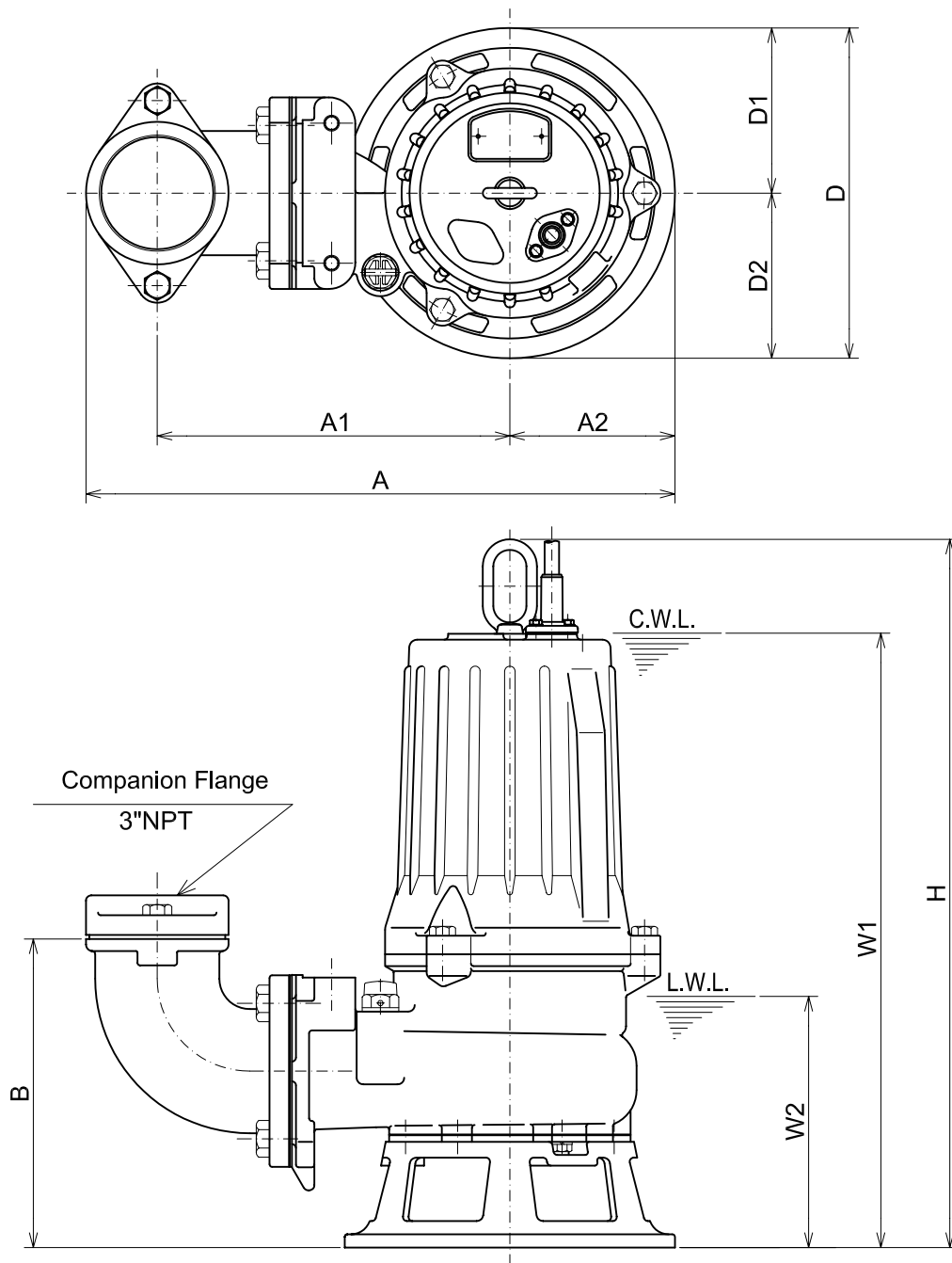

B-SERIES
SEWAGE & WASTEWATER PUMPS

DIMENSIONS

80B21.5 -62



C.W.L. :Continuous running Water Level
L.W.L. :Lowest running Water Level

DIMENSIONS:USCS(Inch)

Model	HP	NOM. SIZE	Pump & Motor								C.W.L.	L.W.L.	Wt. (lbs.)
			A	A1	A2	B	D	D1	D2	H			
80B21.5 -62	2	3"	17 9/16	10 1/2	4 15/16	9 3/16	9 13/16	4 15/16	4 15/16	21 1/8	18 1/4	7 1/2	79

DIMENSIONS:METRIC(mm)

Model	kW	NOM. SIZE	Pump & Motor								C.W.L.	L.W.L.	Wt. (kg)
			A	A1	A2	B	D	D1	D2	H			
80B21.5 -62	1.5	80	446	267	125	234	250	125	125	536	465	190	36



TSURUMI PUMP

**B-SERIES
SEWAGE & WASTEWATER PUMPS**

DIMENSIONS

TOS80B21.5 -62

Guide Rail System
Model : TOS3-80-80 ANSI
Wt. : 64lb.(29kg)

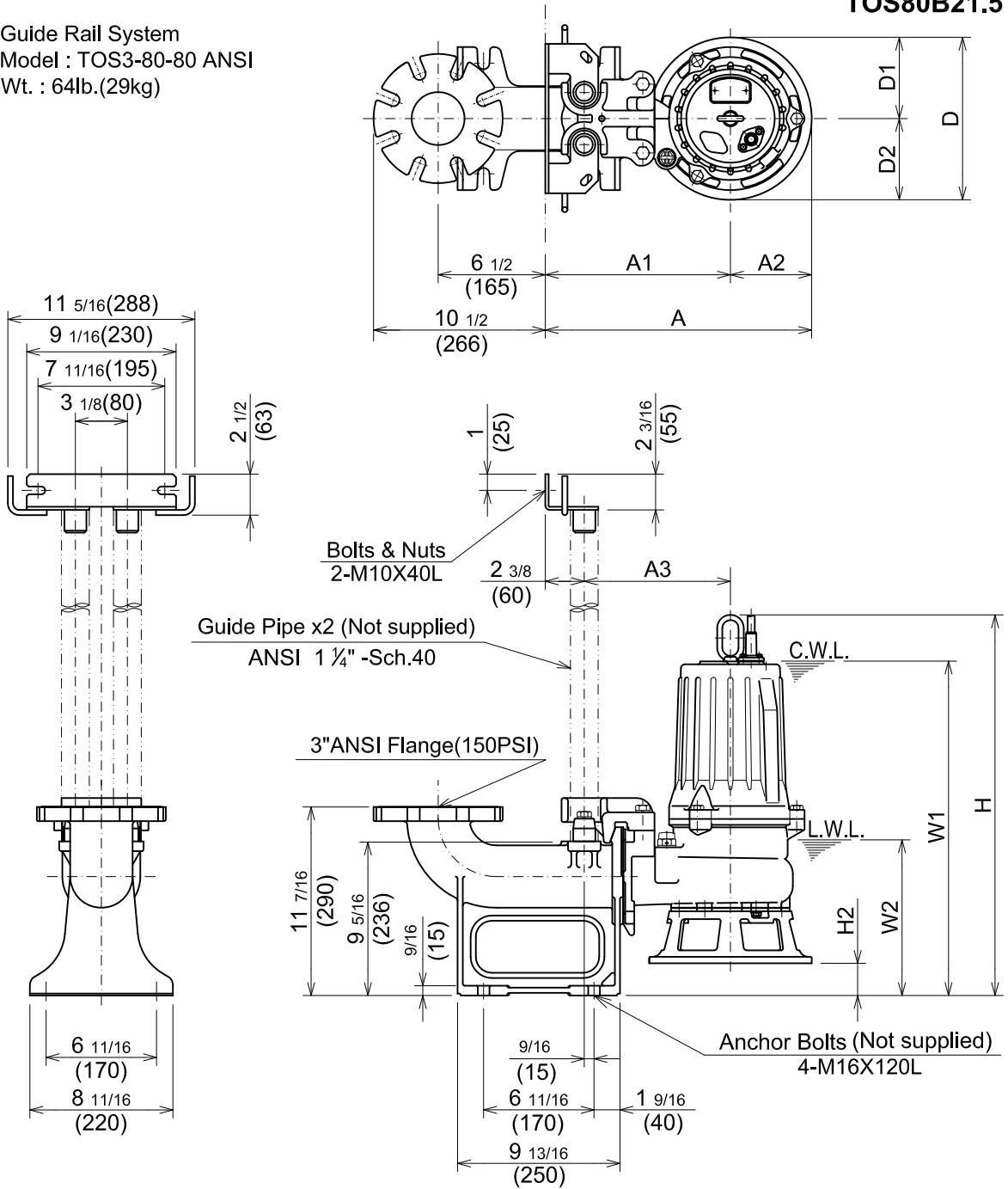

C.W.L. :Continuous running Water Level
L.W.L. :Lowest running Water Level

DIMENSIONS:USCS(Inch)

Model	HP	NOM. SIZE	Pump & Motor									C.W.L.	L.W.L.	*Wt. (lbs.)
			A	A1	A2	A3	D	D1	D2	H	H2			
TOS80B21.5 -62	2	3"	16 1/8	11 1/4	4 15/16	8 7/8	9 13/16	4 15/16	4 15/16	23 1/16	1 15/16	20 1/4	9 1/2	75

DIMENSIONS:METRIC(mm)

Model	kW	NOM. SIZE	Pump & Motor									C.W.L.	L.W.L.	*Wt. (kg)
			A	A1	A2	A3	D	D1	D2	H	H2			
TOS80B21.5 -62	1.5	80	410	285	125	225	250	125	125	586	50	515	240	34

*Excluding TOS & Cable.



TSURUMI PUMP

**B-SERIES
SEWAGE & WASTEWATER PUMPS**

**PERFORMANCE
CURVE**

MODEL	BORE	HP	KW	RPM	SOLIDS DIA.	LIQUID	SG.	VISCOSITY	TEMP.
(TOS)80B21.5 -62	3"/80mm	2	1.5	3400	1.38"/35mm	Water	1.0	1.123cSt.	60°F
PUMP TYPE	PHASE	VOLTAGE	AMPERAGE	HZ	STARTING METHOD	INS.CLASS			
Sewage&Wastewater	3	208-230/460/575	6.2-5.9/3.1/2.3	60	Direct On Line	F			
CURVE No.	DATE	PHASE	VOLTAGE	AMPERAGE	HZ	STARTING METHOD	INS.CLASS		
-	-	-	-	-	-	-	-		

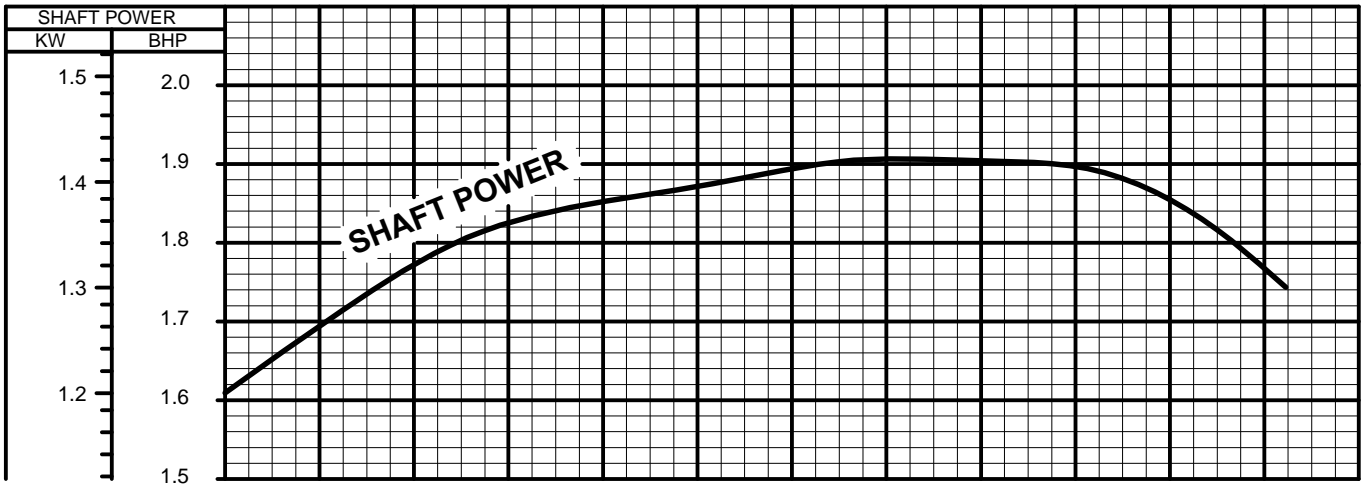
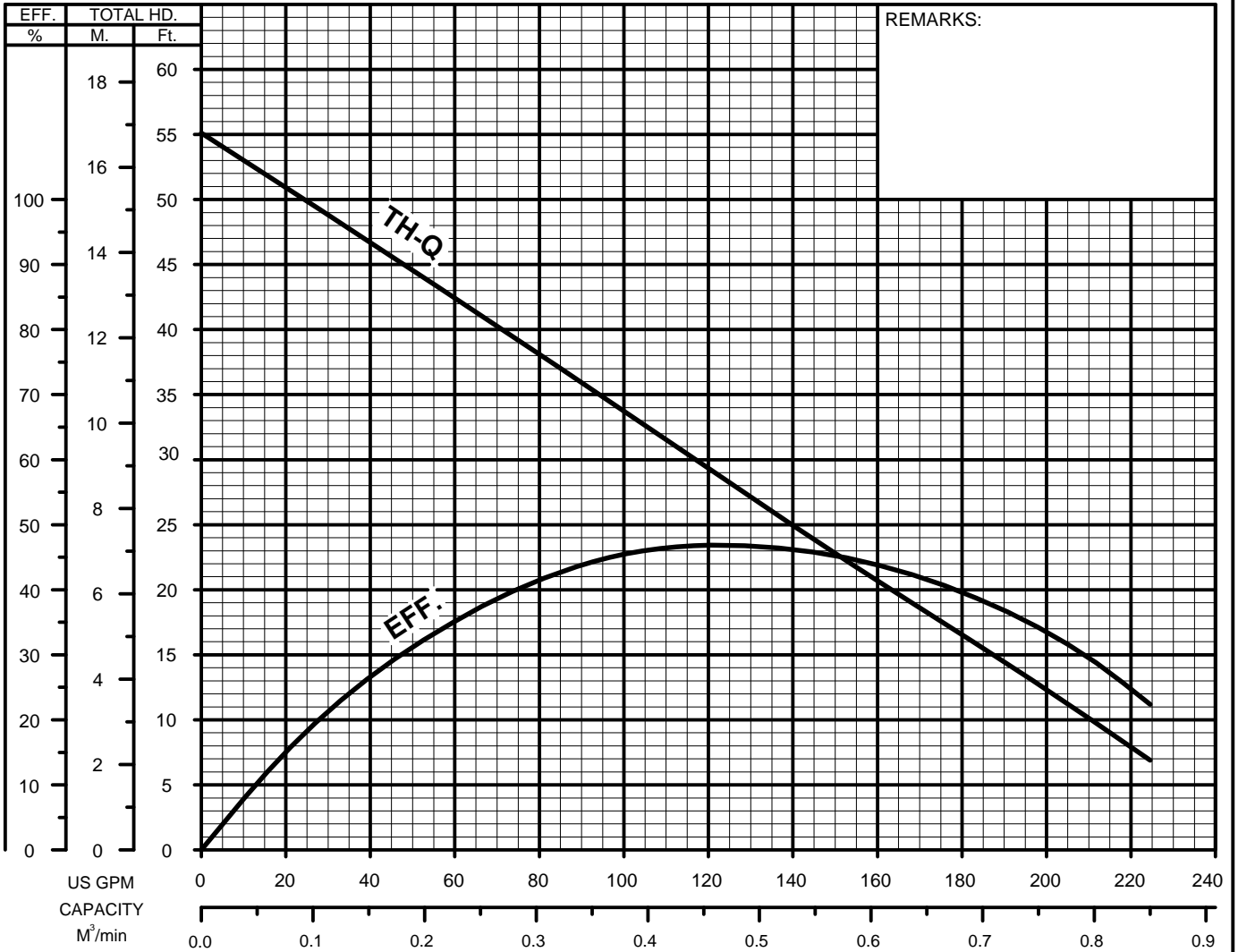

80B21.5 -62

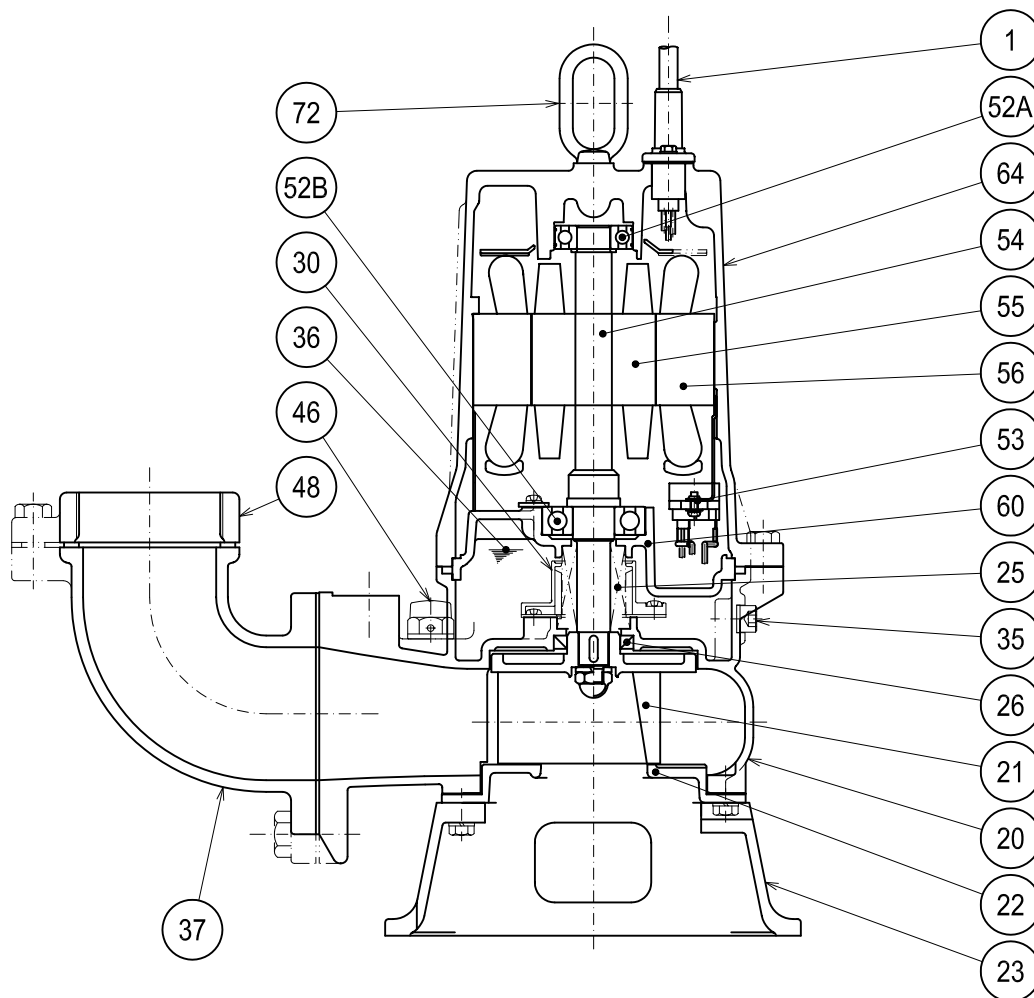

PART#	DESCRIPTION	MAIN MATERIAL / NOTE	RELATED ASTM,AISI CODE	RELATED EN CODE	QTY
1	Power Cable	PVC Sheath AWG 16/4-32ft			1
20	Pump Casing	Cast Iron	A48M Class30B	EN 1561 GJL-200	1
21	Impeller	Cast Iron	A48M Class30B	EN 1561 GJL-200	1
22	Suction Cover	Cast Iron	A48M Class30B	EN 1561 GJL-200	1
23	Suction Strainer	Ductile Cast Iron	A536 65-45-12	EN 1563 GJS-450-10	1
25	Mechanical Seal	Silicon Carbide / H-20			1
26	Oil Seal	NBR / TC32488			1
30	Oil Lifter	PBT Resin W/GF40			1
35	Oil Plug	Stainless Steel	S 30400	1.4301	1
36	Lubricant	Turbine Oil ISO VG32 or SAE 10W-20			
37	Discharge Bend	Cast Iron	A48M Class30B	EN 1561 GJL-200	1
46	Air Release Valve	Nylon			1
48	Companion Flange	Cast Iron / NPT 3"	A48M Class30B	EN 1561 GJL-200	1
52A	Upper Bearing	AC-#6204ZZC3			1
52B	Lower Bearing	#6305ZZC3			1
53	Motor Protector				1
54	Shaft	Stainless Steel	S 42000	1.4028	1
55	Rotor				1
56	Stator				1
60	Bearing Housing	Cast Iron	A48M Class25B	EN 1561 GJL-150	1
64	Motor Housing	Cast Iron	A48M Class25B	EN 1561 GJL-150	1
72	Lifting Lug Bolt	Stainless Steel	S 30400	1.4301	1

PARTS LIST		SEWAGE & WASTEWATER PUMP			1/11/2017	
ITEM	PART No.	DESCRIPTION	QTY	SIZE	MATERIAL	NOTES
1	140-427-17	Hex.Bolt (w/Plain Washer)	2	M5x15	SUS304	
2	003-190-10	Gland	1		SUS316	
3	001-803-20	Cabtyre Cable Set (32')	1	VCT4Cx1.25mm2	LBT	
4	072-000-03	Eye Bolt	1	M10	SUS304	
5	140-076-17	Hex.Bolt	3	M10x30	SUS304	
6	064-000-08	Motor Frame	1		FC	
7	009-211-16	Earth Terminal	1Set	1.25mm2x120L		
8	143-085-34	Pan Screw (w/Spring Washer)	1	M4x6	C3604	
9	142-389-12	Wave Washer	1	6204	SK5	
10	052-187-16	Bearing (w/O-ring)	1	AC-6204ZZC3		
11	058-000-13	Lead Wire Protection Plate	1	d61xd132x2t	Bakelite	
12	061-174-18	Slinger	1	d20xd27x2t	SPC	
13	055-000-01	Rotor	1Set			
14	147-038-18	Impeller Key	1	5x5x15.5l	SUS420	
15	056-001-12	Stator 220V-60Hz	1Set			
	056-001-14	Stator 380/460V-60Hz	1Set			
	056-001-16	Stator 575V-60Hz	1Set			
16	127-000-26	Protector Fixing Plate	1	KA313,d145	SPCC	
17	053-000-01	Motor Protector 220V-60Hz	1	KA313-GBTL103	(T.C)	
	053-000-10	Motor Protector 380/460V-60Hz	1	KA311-DPXL78	(T.C)	
	053-000-11	Motor Protector 575V-60Hz	1	KA311-FPVL78	(T.C)	
18	143-126-12	Pan Screw (w/Spring Washer/Plain Washer)	2	M4x12	SWRM	
19	052-108-13	Bearing	1	6305ZZC3		
20	140-000-23	Hex.Bolt (w/Spring Washer)	2	M5x10	SWRM	
21	062-187-17	Bearing Fixing Washer	2	d5.5xd18x2.3t	SPC	
22	060-000-16	Bearing Housing	1		FC	
23	025-252-19	Mechanical Seal	1	H-20A	SiC+CCBN	
24	143-070-23	Pan Screw	2	M5x6	SWRM	
25	030-144-13	Oil Lifter	1	H-20(A)(T)	Resin	
26	143-070-10	Pan Screw	2	M5x6	SWRM	
27	030-153-15	Seal Stopper	1	H-20(A)	SPCC	
28	122-145-12	O-Ring	1	G-170(169.3xd5.7)	NBR	*
29	020-001-44	Pump Casing	1	15-BE2	FC	
30	046-107-13	Air Release Valve	1	PT-1/2	Nylon	
31	035-124-12	Oil Plug	1	M10x15	SUS304	
32	121-246-11	Packing	1	d10.3xd16x2t	PE	*
33	026-107-11	Oil Seal	1	TC-32488	NBR	
34	040-104-25	Impeller Shim		d18.2xd29x0.3t	SUS304	

PARTS LIST		SEWAGE & WASTEWATER PUMP			1/11/2017	
ITEM	PART No.	DESCRIPTION	QTY	SIZE	MATERIAL	NOTES
35	021-758-21	Impeller (50Hz) OPTION	1	80B21.5-52	FC	50Hz OPTION
	021-759-22	Impeller (60Hz)	1	80B21.5-62	FC	
36	142-165-10	Spring Washer	1	M12	SUS304	
37	141-118-15	Hex.Cap Nut	1	M12(H=15.5)	SUS304	
38	120-146-17	Packing (S.Cover)		d136xd157x0.3t	PE	
39	022-572-19	Suction Cover	1	15-BE2	FC	
40	140-475-10	Hex.Bolt (w/Spring Washer)	3	M8x16	SUS304	
41	023-001-25	Strainer Stand	1	80B/C21.5-52/62	FC	
42	140-488-16	Hex.Bolt (w/Spring Washer)	3	M8x30	SUS304	
43	140-099-16	Hex.Bolt	2	M12x40	SUS304	
44	048-137-18	Screwed Flange	1	3" NPT (PC140)	FC	
	048-136-17	Screwed Flange	1	2" NPT (PC140)	FC	2" OPTION
45	121-137-18	Packing	1	MBT(P.C.140)	NBR	*
46	037-118-19	Discharge Bend	1	80mm(123-17)	FC	
47	140-123-10	Hex.Bolt	4	M16x35	SUS304	
48	121-152-19	Packing	1	145mm2(P.C.145)	NBR	*
	173-338-12	Packing O-Ring Set	1Set	(Marked by *)		
28	122-145-12	O-Ring (M.Frame/P.Casing)	1	G-170(169.3xd5.7)	NBR	*
32	121-246-11	Packing (Oil Plug)	1	d10.3xd16x2t	PE	*
45	121-137-18	Packing (Screwed Flange)	1	MBT(P.C.140)	NBR	*
48	121-152-19	Packing (Discharge Bend)	1	145mm2(P.C.145)	NBR	*
		Lubricant		Turbine Oil VG32 900ml		

PARTS LIST		SEWAGE & WASTEWATER PUMP				1/11/2017
ITEM	PART No.	DESCRIPTION	QTY	SIZE	MATERIAL	NOTES

EXPLODED VIEW

80B21.5-52/62

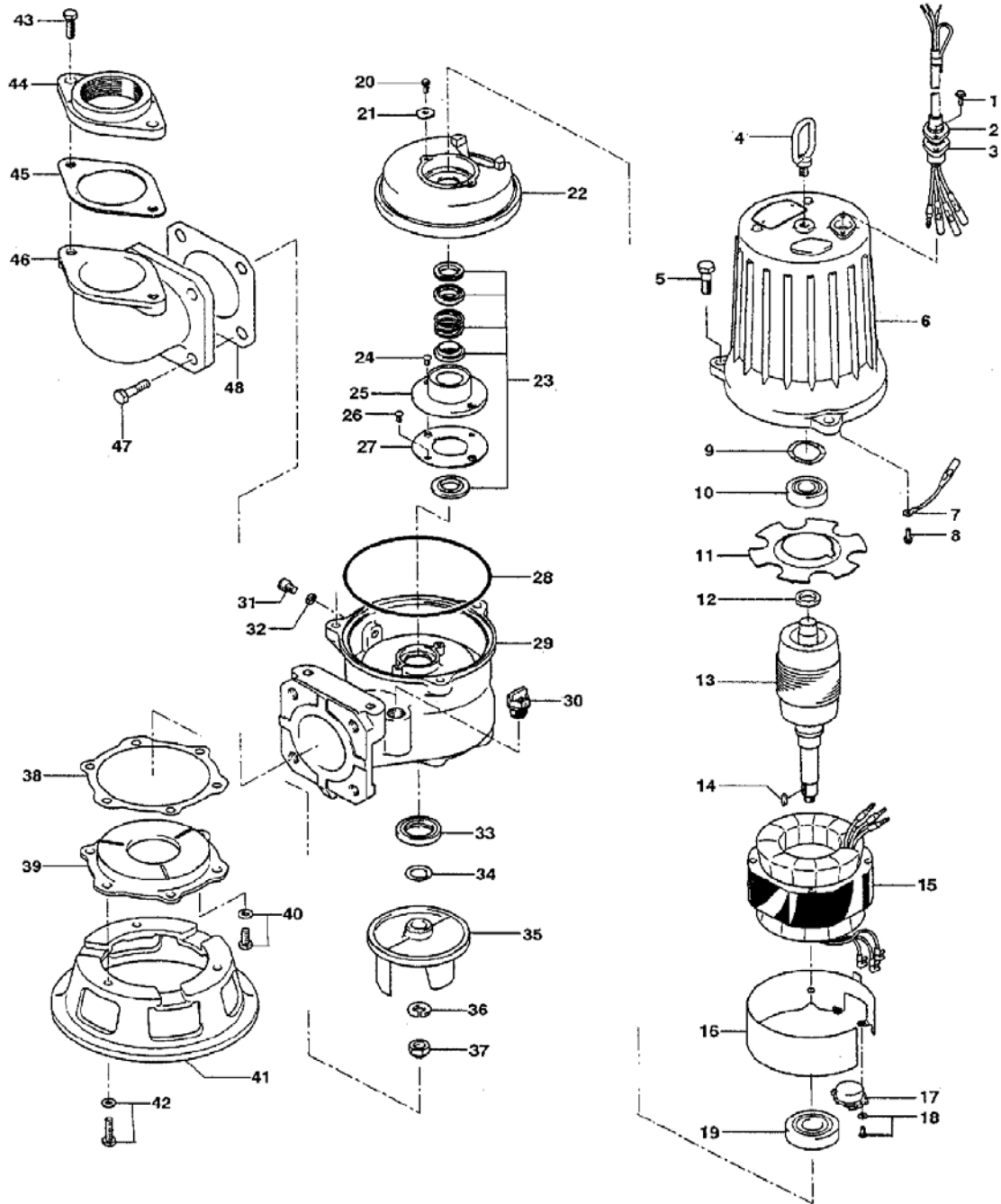

C-00569-1